



User' s Manual Of Electric Vehicle Charging Pile Controller

Instruction for use

1.1 About the manual

The instructions contain all the information needed for debugging and using the controller. Only the staff with electrical technology can debug the controller.

Validity range of this manual

This manual is valid for all parts of the charging pile controller.

This product is based on international standards IEC61851 and SAEJ1772.

Note: SAEJ1772 is a standard for electric vehicle chargers proposed by the Society of Automotive Engineers.

1.2 Recycle and treatment

The material of the controller has environmental compatibility and can be recycled. In order to meet the environmental protection requirements, please contact a certified professional company that specializes in handling such waste to deal with electronic waste.

Safety Instruction

2.1 Precautions and hazards

Note: please follow the safety instructions and legal guidelines.

Due to the different installation requirements in different countries and regions, the installation personnel are responsible for ensuring that the product installation can meet the local legal requirements.

Danger: voltage hazard

Contact with live components will cause serious injury. Please cut off the power supply of all systems and devices before operation.

2.2 Fuse

Warning: improper fusing may cause heat or fire

The internal self-resetting fuse is only used to protect the controller, and the installation personnel are responsible for the safety of the circuit.

2.3 Repair

It is not allowed to repair, and the defective device shall be disposed (abandoned) under the condition of meeting the environmental protection requirements.

Warning: opening the device without permission can cause danger

Opening the device without permission may cause harm to the user or cause significant damage or property loss.

Note: if the device is changed in violation of regulations, the manufacturer's warranty will be invalid.

Any unauthorized changes will void the warranty.

Description

3.1 Controller Features

The controller is a kind of product suitable for charging pile of electric vehicle.



- (1) Software correction instructions, such as EKEPC1 or EKEPC2
- (2) Maximum charging capacity indication 10A, 16A, 20A, 25A, 32A, Through the internal dial switch (The factory default setting is 32A).
- (3) "C" for the cable version and " S" for the socket (without cable) version

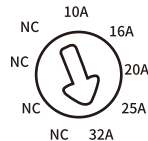

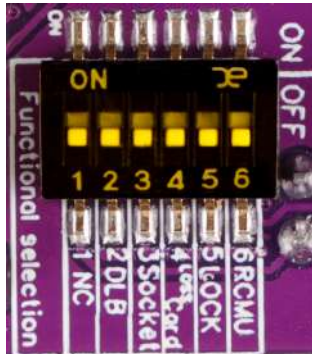
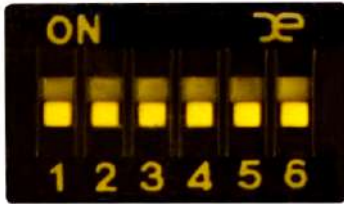

Select controller additional functions:

Switch the DIP switch to "ON" which corresponding to the functions you need

The functions of the corresponding positions are described as follows: In the "ON" position

2:DBL current balance working mode

3:Socket version working mode

4:Function with RFID

5:With electronic lock function

6:Added RCMU(DC6mA) module function

The functions of the corresponding positions are described as follows:

In the "OFF" position

2:Normal working mode

3:Cable version working mode

4:Lost(without) IC card working mode

5:Without electronic lock function

6:None RCMU(DC6mA) function

External can connection LCD

Scope of use

The communication to control the charging procedure of electric vehicle conforms to electric vehicle standard IEC61851 or SAEJ1772.

According to DIN EN60715 installation requirements.

The output of the relay is used to connect the switching load contactor.

The operation status of vehicle interface is displayed by LED.

The controller can be connected to the following external functions:

contactless IC card connection module, DC leakage detection module (rcmu), RS485 communication interface equipment, gun head lock device (DC12V), external emergency stop button. These functions need to be explained when ordering.

3.2 Application cases

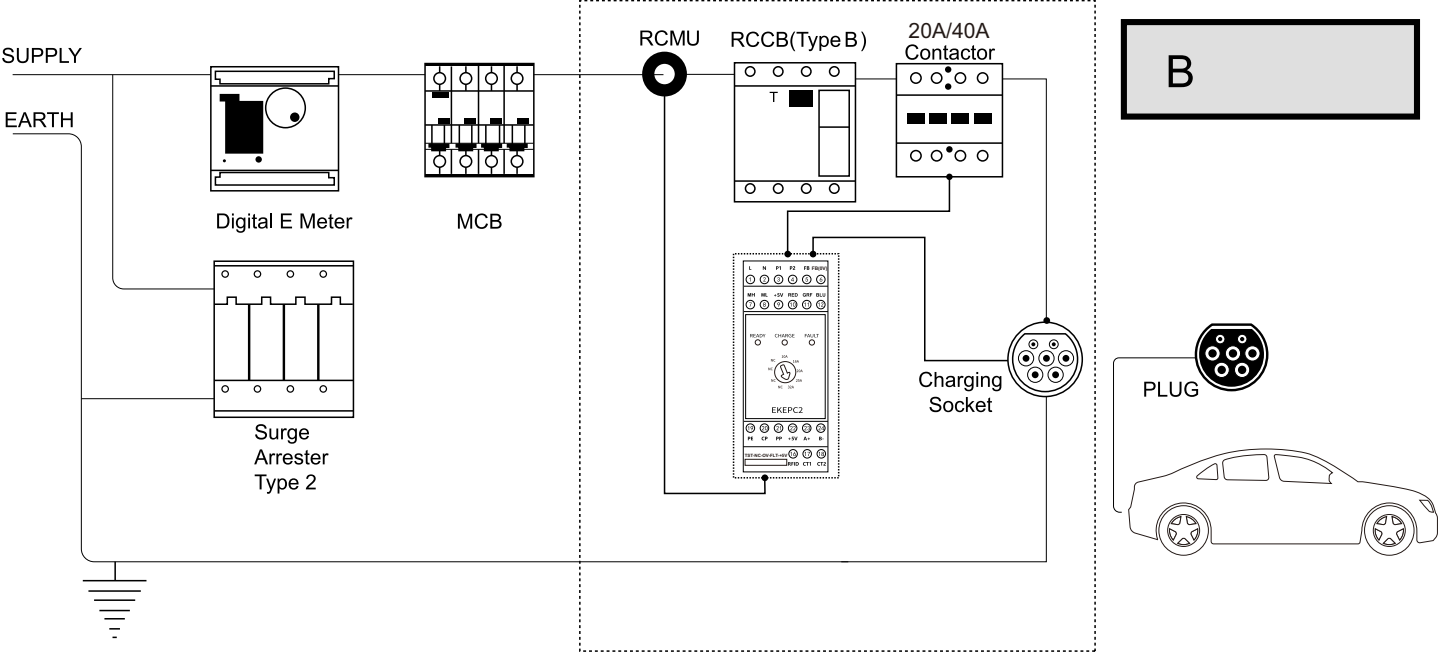

3.2 Application cases

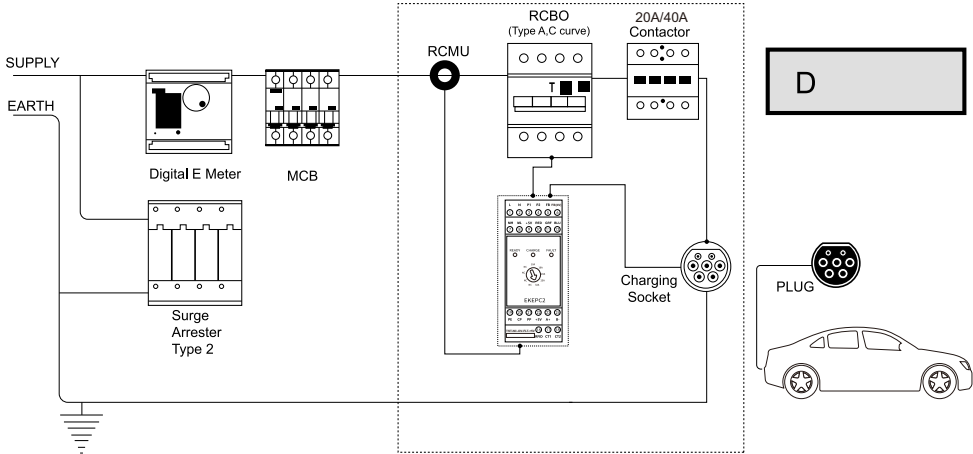
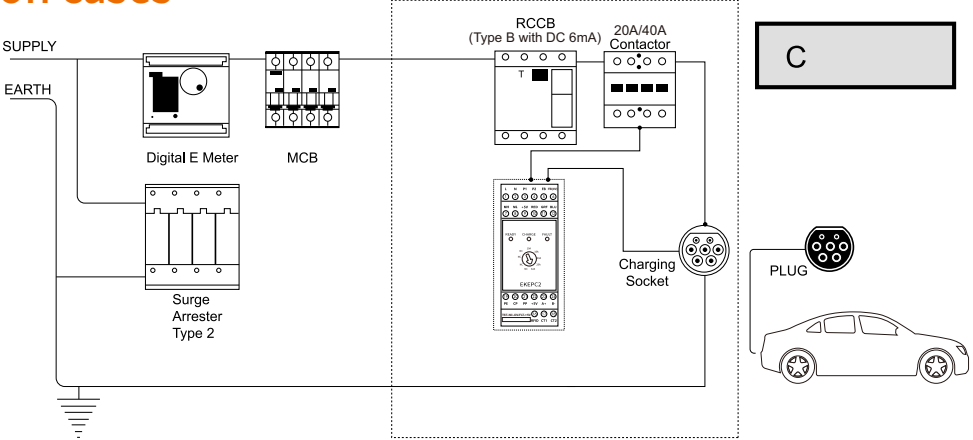

3.2 Application cases

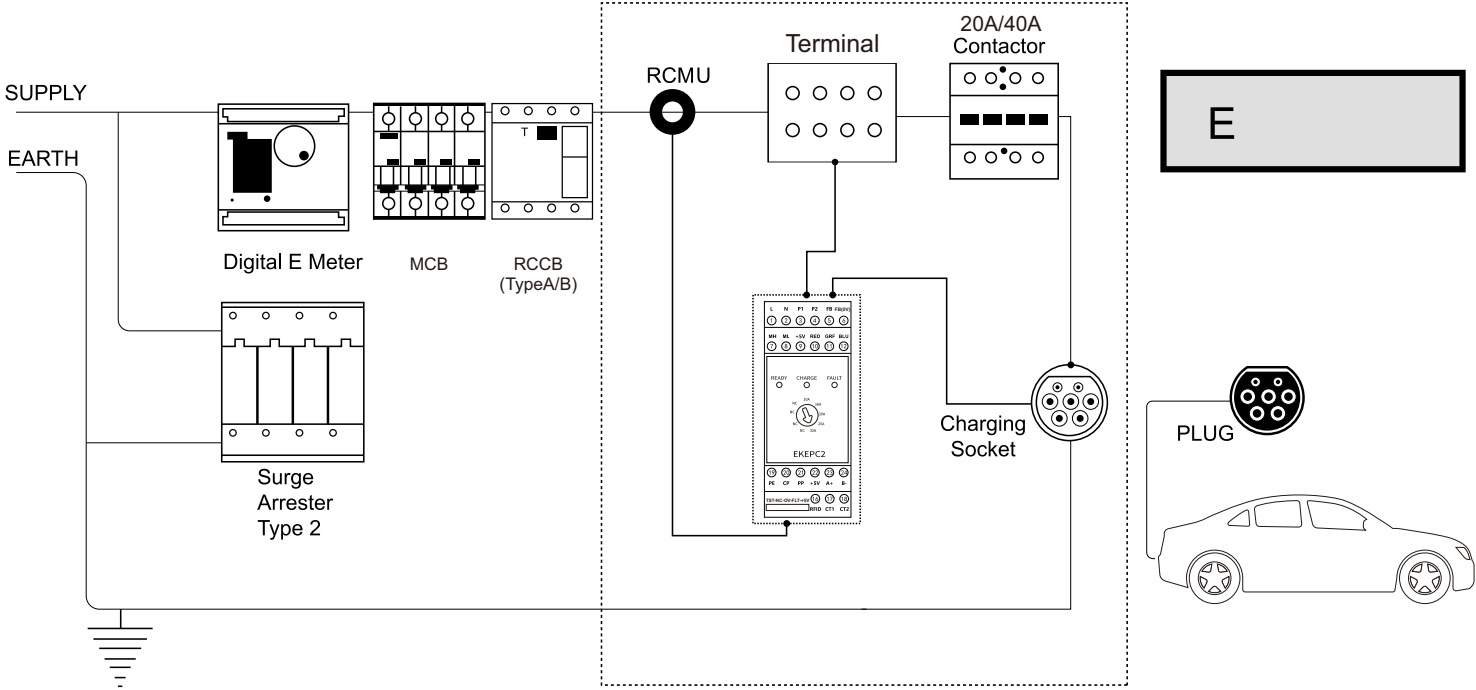

3.2 Function description

3.3.1 Charging process of controller with cable type (only CP signal is needed)

After switching on the working voltage, the module starts to initialize and perform the function self-test (LED light flashes circularly), waiting for the car to connect. The controller waits for the charging cable to connect to the vehicle (status a), and the LED flashes blue continuously. If the cable matching with the controller has been connected (state B), the LED turns to stable blue light and turns on the electromagnetic lock switch. After the gun head interlock, if the vehicle is in State C, the controller will make P1/ P2 in closed state (connected state), and the LED will turn to stable green light. If status D (ventilation required) is displayed, because the controller has no heat dissipation function, the controller makes P1 / P2 in the open state (off state) and turns off the electromagnetic lock switch at the same time, the gun head interlock will be invalid, and the controller will turn off the charging procedure, and the LED will turn into a stable red light.

3.2 Function description

3.3.2 Charging process of controller without cable type(socket type)(connecting CP and CS signals)

Before the power is turned on, the CS signal port of the controller can not be connected to any device,after the working voltage is turned on, the module starts to initialize and perform function self-test (LED lights flash circularly), waiting for the connection of the car cable,this lights flash circularly), waiting for the connection of the car cable,this process takes about 10 s.e. The controller waits for the charging cable to connect to the vehicle (status A), and the LED flashes blue continuously. If the cable matching with the controller has been connected (state B), the LED turns to stable blue light and turns on the electromagnetic lock switch(if have). After the gun head interlock(if have), if the vehicle is in State C, the controller will make P1 / P2 in closed state (connected state), and the LED will turn to stable green light. If status D (ventilation required) is displayed, because the controller has no heat dissipation function, the controller makes P1 / P2 in the open state (off state) and turns off the electromagnetic lock switch(if have) at the same time, the gun head interlock will be invalid, and the controller will turn off the charging procedure, and the LED will turn into a stable red light.

In E and f States, the LED will not be on again when the electromagnetic lock switch is off and the controller turns off the charging procedure.

In the fault state, the controller turns P1 / P2 on (off) and turns off the electromagnetic lock switch.

The LED turns red and flashes continuously.

Ventilation requirements

In the absence of ventilation, the risk of asphyxiation may be caused due to the accumulation of some battery related gases when charging indoor. If the charging process is carried out indoor, forced ventilation shall be installed, the charging pile controller does not have forced ventilation function.

Connection confirmation line (CS) current, resistance correspondence information.

current resistance/ current resistance/ current resistance / current resistance/ current resistance

32A 732Ω / 25A 536Ω / 20A 432Ω / 16A 348Ω / 10A 249Ω When the input resistance (minimum) is lower than 100Ω, it cannot be charged or interlocked. The controller will reduce the current load to 7a within 5S, and the controller will enter Status A until the resistance value of the input current rises.

3.4 LED display and troubleshooting

LED Display

There are three colors of display, the specific working status and functions are as follows:

Controller connection status

No.	State Code	LED Color	LED State	PE、CP、PP state	Controller state	Remark
0	K	Red	5Hz flashing	Power self detect failed	Fault--1#	Power self-check failed! Please turn the power back on!
1	A	Blue	1Hz flashing	CP disconnection	Ready	
2	I	Blue	2Hz flashing	Waiting for IC card	RFID Waiting	
3	B	Blue	Stabilization	CP connect to diode+2.7KΩ	Connected	
4	B	Blue	Stabilization	CP connect to diode+1.3KΩ	Connected	
5	C	Green	Green brightening	CP connect to diode+2.7KΩ parallel connect 1.3KΩ	Charging	
6	D	Red	Stabilization	CP connect to diode+2.7KΩ parallel connect 1.3KΩ parallel connect 270R Or CP connect to diode+270R Or CP connect to diode+270R parallel connect 2.7KΩ Or CP connect to diode+270R parallel connect 1.3KΩ	Fault--2#	Need Ventilation!
7	F	Red	1Hz flashing	CP line short circuit with PE line	Fault--3#	CP- PE short circuit! Please check the CP line
8	H	Red	5 Hz flashing	RCMU occurs residual current or self detect failed	Fault--4#	RCMU leakage or self-inspection failure
9	E	Red	2Hz flashing	Diode short circuit (Requirement waiting the CP disconnected)	Fault--5#	EV-Charing Socket Fault
10	G	Blue+Red	2Hz flashing	PP line disconnection	Fault--6#	SPLIT PP wire, Please check the PP line
11	J	Red+Green+Blue	2Hz flashing	Electromagnetic Lock failed	Fault--7#	Electronic Lock Disabled
12	L	Blue	5Hz flashing	IC card failed	Fault--8#	RFID card is not valid
13	M	Red+Green	1Hz flashing	Circuit overload, DLB Mode activated	Fault--9#	Circuit overload, DLB Mode activated

Installation

4.1 Installing to DIN rail

1. Install the controller (a) vertically on the horizontal DIN rail (b).
2. Rotate the device down until the slider on the DIN rail snaps in.

(Note: DIN rail: rail in accordance with German industrial standards)

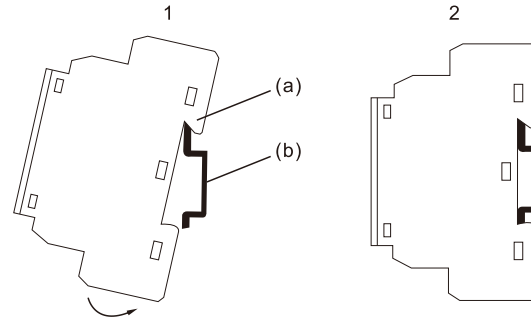

Wiring

Warning: improper (connection) fuses can cause heat or fire.

The internal self-reset fuse is designed only for the protecting device itself, and it is the responsibility of the controller's user or factory operator to protect the circuit related to the control.

This device does not include the contactor of load output. Improper use of the contactor of load output will cause heat or fire when the line is overloaded. The contactor of load output is installed from outside by the factory operator.

Warning: through the controlling signal, the maximum charging current borne by the vehicle shall not exceed the maximum charging current specified by the EPC controller, otherwise personal injury or property loss will be caused.

Notice

L/N is connected to the main board' s line.

5.1 Connecting terminal blocks and terminal assignment



“C: with cable version” means that the charging cable is permanently connected to the controller; P1 / P2 terminal is connected to the AC contactor providing the charging load. The rated value of Curve B circuit breaker shall be selected within the maximum current range circuit breaker shall be selected within the maximum current range

STRIPPED LENGTH	RERMISSIBLE CONDUCTOR CROSS-SECTIONS OF TERMINALS	LINE TYPES ACCORDING TO AWG
	0.5...2.5 mm ²	20...14
 Finely Stranded	<ul style="list-style-type: none"> with come ends prepared: 0.5...2.5 mm² without come ends prepared: 0.5...2.5 mm² 	20...14

Notice

When selecting the cable, its temperature resistance needs to be at least 75°C. If the temperature resistance fails to meet the requirements, personal injury or property loss will be caused.

Warning: The conductor sections should be designed to conform to the standard system construction. The cable must conform to the type of line, otherwise it will cause personal injury or property loss.

Terminals arragemnet specification

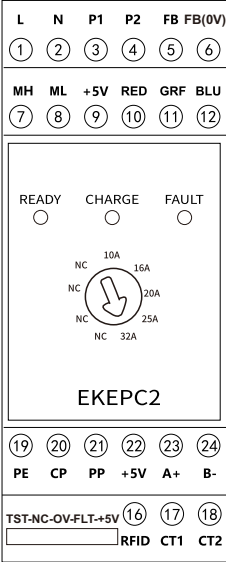

Terminal function specification

Serial number	Mark	function	Specification
1	L	Live line	Product working power supply:AC230V±10% 50Hz
2	N	Neutral line	
3	P1	Relay/contactor A1 connect to L P1 connect to N	AC contactor connected to the connection load of charging station
4	P2	Relay coil A2	
5	FB	Reflect signal of the electromagnetic lock	This is the feedback signal on the electromagnetic lock directly to the passive contact output terminal of the electromagnetic lock
6	FB0V		
7	MH	Electromagnetic lock positive voltage	Provide positive and negative pulse voltage of electromagnetic lock, duty cycle of output pulse (1: 3) and total pulse output maximum driving capacity of 500ms
8	ML	Electromagnetic lock negative voltage	
9	+5V	DC +5V	External indicator light, DC5V/10mA drive capability
10	RED	Red LED	
11	GRE	Blue LED	
12	BLU	Green LED	

Terminal function specification

Serial number	Mark	function	Specification
13	TST	RCMU fault signal(DC5V), output terminal	When the controller detects this end signal, means this line occur fault (including \geq DC6mA leakage signal), the controller will cut off the charging power, untill this fault signal is solved , the controller will automatic resumes the charging state.
14	NC		
15	OV FLT +5V		
		RCMU test signal(DC5V), the input terminal	The controller outputs the test signal before each charging, using to check that the working of the RCMU whether normal
16	RFID	RFID-controlied input signal	The signal of external non-contact IC card reading module,input is TTL voltage signal,DC 3.3V/5V
17	CT1	Current transformer	When the controller requires DLB function, it requires connect to current transformer signal, the signal is: AC0-5A. This function can dynamically balance the power load, adjust the output in time, control the charging current, and protect the safety of the power supply line.
18	CT2		
19	PE	Power supply	Earth terminal
20	CP	Connect to the vehicle CP	Communication connection with electric vehicle, output PWM wave
21	PP	Charging cable current identification	When this end is a socket type charging station, it identify the current specification of charging cable
22	+5V	+5V Power Supply	Supply DC 5V/100mA power output
23	A+	A +for RS485 Communications	It can communicate with RS485 equipment. The communication standard conforms to Modbus-RTU slave mode. Baud rate: 38400, N, 8, 1 address number default: 255(Broadcast address) See Table A for details
24	B-	B-for RS485 Communications	

Single Phase

Wiring example 230V AC

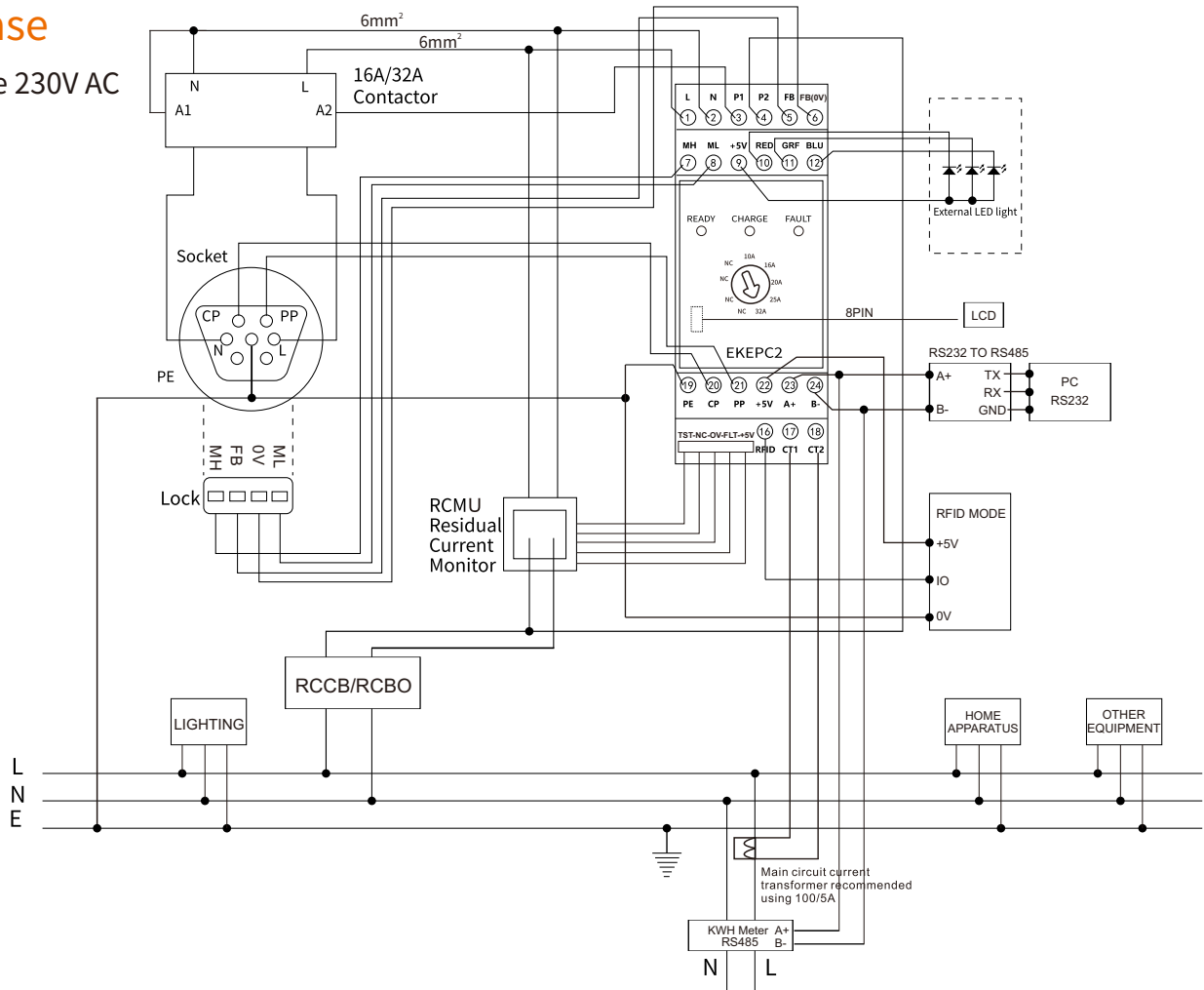

Three Phase

Wiring example 400V AC

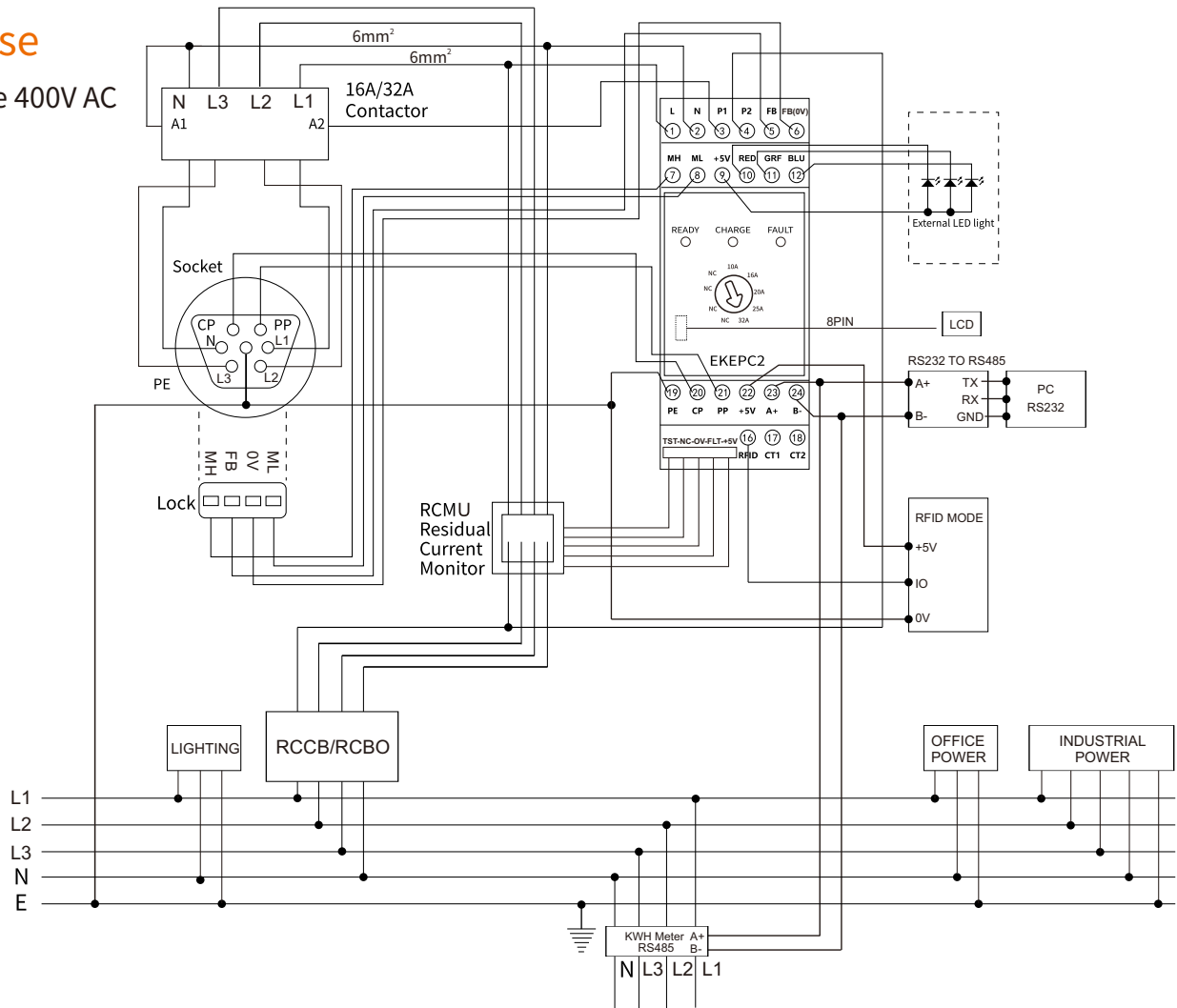

Wiring instructions

Controller signal line P1: Blue 1.5 mm²

Controller signal line N : Blue 1.5 mm²

Contactor coiling opening and closing line N: Blue 1.5 mm²

Power output line N: Blue 6mm²

Continuous output line N: 1.5 mm²

Contactor coiling opening and closing line L: Brown 1.5 mm²

Controller signal line L : Brown 1.5 mm²

Continuous output line L: 1.5 mm²

Power output line L: 6 mm²

WAGO 1

WAGO 2

Curve B RCCB

Controller

Contactor

Terminal blocks

Input line

Input line of charging plug

Two colors signal grounding wire 1.5 mm²

Black signal wire 0.5 mm²

Brown outgoing line L: 6 mm²

Blue outgoing line N: 6 mm²

Two colors grounding wire: 6 mm²

5.3 Functional grounding

Vehicle interface shall conform to IEC61851

1. Connect “CP” directly to the interface of vehicle charging terminal.
2. Firstly connect the ground wire (PE line) of the vehicle charging terminal interface to the OV control point of the EPC controller, and then connect other lines in order. Do not use terminal blocks or EPC controller to connect the device from the outside at OV control point.

OV control point shall be consistent with the expected current of the factory. The connection of EPC controller to OV is functional grounding, and the reliability of connection must be guaranteed, otherwise personal injury or property loss will be caused.

5.4 Relay output

We recommend connection with 230 / 400V 10kA Type B RCCB.

Cutting off the power branch

According to IEC61851, it is required to cut off the power branch when the charging process is completed within 100ms.

The EPC controller will stop the relay output after detecting that the power branch is cut off.

Warning: To cut off the power branch, especially the contactor, the total power-off time shall not exceed the required 100ms.

Replacement device

Maintenance

EPC charging controller is maintenance free.

Warning: There is no replaceable fuse inside EPC. When replacing, make sure that the device and the components associated with the device are not energized.

Danger: Voltage hazard

Touching any running parts will cause serious injury. Please cut off the power before operation.

Process

1. Cut off the line from the EPC controller terminal.
2. Pull the latch down from the back of the unit and rotate until it is free of the DIN rail and removed.
3. Installation: connect the rear lock clipper to the DIN rail and swing until the lock clipper was put in.
4. Reconnect the line (On).
5. Turn on the switch and the main power.

Cleaning

Cleaning of the unit is not allowed.

Dimensional drawings(mm)

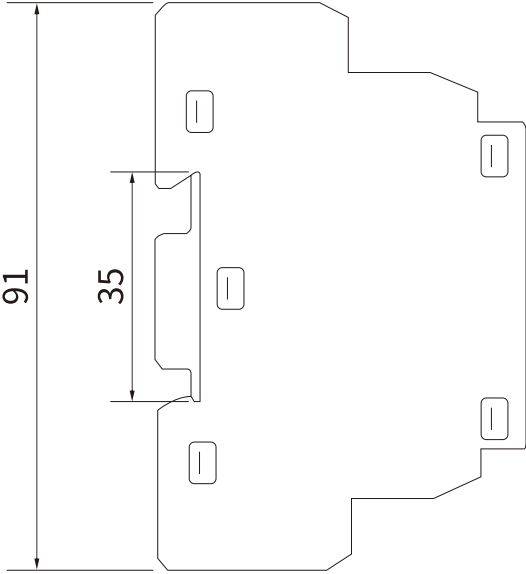
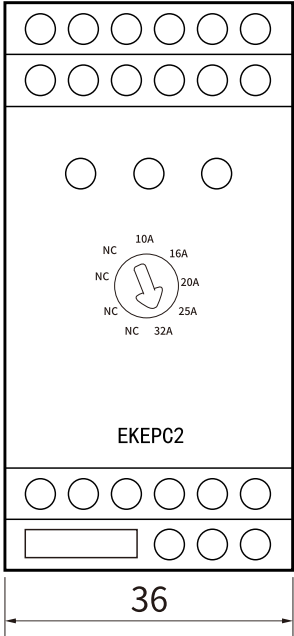

RS485 Communication description

Modbus-RTU model, Baud rate: 38400,n,8,1 fixed, address: 1-255 default: 255 (Broadcast address)

Register address number	Data description (power failure protection)	Read and write	Type of data	Defaults
100	Device address number	Read and write	16-bit integer	255
101	DLB maximum starting current	Read and write	16-bit integer	3500
102	DLB maximum current (100.00A)	Read and write	16-bit integer	4500
103	Reference current: DLB/current transformation ratio (100.00A)	Read and write	16-bit integer	10000
104	Reference current calibration value input	Read and write	16-bit integer	1270
105	Charging pile current transformation ratio 50-200A	Read and write	16-bit integer	
106	Charging pile current value correction 0-100.0A	Read and write	16-bit integer	
107	Charging pile voltage value correction 0-500.0V	Read and write	16-bit integer	
108	Charging pile power value correction 0-22000W	Read and write	16-bit integer	
109	Maximum output PWM duty cycle of charging pile	Read and write	16-bit integer	9000
110	RCMU function selection 0 disabled 1 enabled, other values are selected by DIP switch	Read and write	16-bit integer	3
111	RFID function selection 0 disabled 1 enabled, other values are selected by DIP switch	Read and write	16-bit integer	3
112	Lock function selection 0 disabled 1 enabled, other values are selected by DIP switch	Read and write	16-bit integer	3
113	Cable function selection 0,Socket function selection 1 by DIP switch	Read and write	16-bit integer	3
114	DLB function selection 0 disable 1 enable, other values are selected by DIP switch	Read and write	16-bit integer	3
115	PID control parameter P of DLB	Read and write	16-bit integer	100
116	PID control parameters of DLB I	Read and write	16-bit integer	1
117	DLB PID control parameter D	Read and write	16-bit integer	100
118-119	Controller ID number up to 9 digits	Read and write	32-bit	
120	Rated temperature	Read and write	16-bit integer	
121	Temperature correction (Input how much difference between real and display)	Read and write	16-bit integer	
122	Start Temperature	Read and write	16-bit integer	
123	Stop Temperature	Read and write	16-bit integer	
124	Frequency correction(Input how much difference between real and display)	Read and write	16-bit integer	
126	Pole option:1P 3P(Default is 1P)	Read and write	16-bit integer	
127-139	Spare	Read and write	16-bit integer	
140	Software version	Read only	16-bit integer	
141	Current working status: Corresponding status 0-13	Read only	16-bit integer	
142	PWM value of cable specification	Read only	16-bit integer	
143	RCMU status 00 Not selected 01 Normal operation 02 Self-check failed 03 There is leakage in the charging circuit	Read only	16-bit integer	
144	RFID status 00 not selected 01 IC card not operating 02 IC card closed 03 IC card open	Read only	16-bit integer	
145	Lock status 00 not selected 01 locked 02 unlocked 03 fault	Read only	16-bit integer	
146	The current current, the decimal place is determined by the value of the reference current	Read only	16-bit integer	
147	Current value of charging pile 0-200.0A	Read only	16-bit integer	

RS485 Communication description

Modbus-RTU model, Baud rate: 38400,n,8,1 fixed, address: 1-255 default: 255 (Broadcast address)

Register address number	Data description (power failure protection)	Read only	Type of data	Defaults
148	Current voltage value of charging pile 0-500.0V	Read only	16-bit integer	
149	Current power value of charging pile 0-22000W	Read only	16-bit integer	
150	Calibration value AD value of reference current	Read only	16-bit integer	
151	The PWM duty cycle corresponding to the current set by the rotary switch	Read only	16-bit integer	
152	Current output PWM duty cycle	Read only	16-bit integer	
154	CP negative voltage	Read only	16-bit integer	
155	Extra small current count	Read only	16-bit integer	
156	Small current count	Read only	16-bit integer	
157	Current Temperature	Read only	16-bit integer	
158	Current Temperature AD value	Read only	16-bit integer	
159-160	Spare	Read only	16-bit integer	